

Rebling Datasheet: 100 amp TFT-style Feed-through Terminal

Our TFT-style terminal provides 100 amp continuous current performance, can be mounted to metal or plastic panels from 0.03" to 0.16" (0.6 to 4.0 mm) thick, it exhibits the same 2,000 volt rating and water-tight properties as the other members of our feed-through terminal family. The TFT's innovative design eliminates the need for auxiliary panel-mounting hardware and accepts optional rigid and flexible covers. Equipping your smaller lithium battery modules or power conditioning modules with the TFT enables your product to fit into the tight spaces allocated by your end users.

Electrical

Current each current profile causes a max 30° C temperature rise when tested per IEC 61984

Current Profile #1	Continuous Rated Current (CRC)	-----	100 amps
Current Profile #2	50% CRC for 60min + 1 sec peak + 50% CRC for 60 min		600 amps
Current Profile #3	50% CRC for 60min + 10 sec peak + 50% CRC for 60 min	-----	400 amps
Current Profile #4	50% CRC for 60min + 30 sec peak + 50% CRC for 60 min		300 amps
Current Profile #5	50% CRC for 60min + 60 sec peak + 50% CRC for 60 min	-----	200 amps

Voltage & Resistance

Continuous Rated Voltage	UL1977 Section 17	2,000 volts
Minimum Dielectric Withstanding Voltage	UL1977 Section 17	5,000 volts
Insulation Resistance	MIL-PRF-18148D Section 3.12.6	500 mega-ohms
Maximum Contact Resistance	MIL-STD-202H Method 307	150 micro-ohms

Mechanical & Environmental

Flammability Rating:	Terminal and Covers	-----	UL 94	V-0
Environmental Sealing:	with Optional O-ring	-----	IEC 60529	IP68+ watertight
	without Optional O-ring		IEC 60529	IP65
Operating Temperature:	Terminal and Rigid Cover	-----		-40 to +125 C
	Flexible Cover			-40 to +90 C
Mechanical Shock		MIL-STD-202H Method 213 Condition A		50 Gs – 3 axes
Vibration		MIL-STD-202H Method 204 Condition A		10 Gs – 3 axes
Panel Thickness Required for Mounting –	Minimum	-----		0.025" (0.6 mm)
	Maximum			0.157" (4.0 mm)
Maximum Wire Size:	Terminal Only	-----		1 AWG (40 mm ²)
	with Rigid or Flexible Snap-On Cover			2 AWG (32 mm ²)

Compliance & Conformance

RoHS, REACH, CMRT/3TG
 UL and CE Conformance

All parts listed on this datasheet are RoHS, REACH and CMRT/3TG Compliant
 Declarations of UL and CE Conformity can be downloaded from Rebling.com

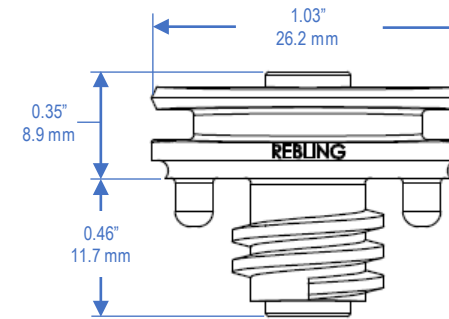

0.28" (7.1 mm) diameter nickel-plated brass conductor with two M5-0.8 tapped blind holes

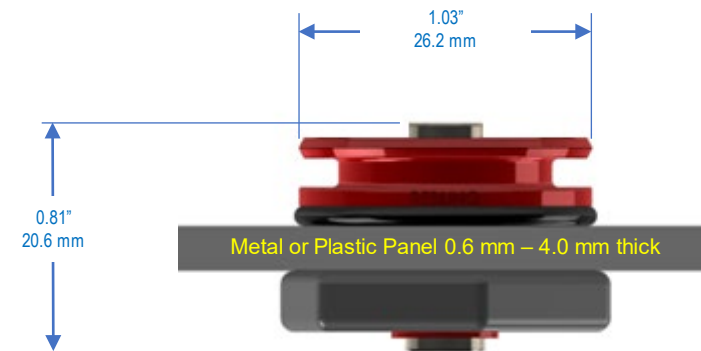

For complete dimensions, download 3D Step files of Terminal and Accessories at Rebling.com



P/N	Description	Plastic Color	Weight (Grams)	Min Thick (mm)	UL 94 Rating	UL Material Yellow Card # **
TFT-P-B	Terminal Kit*, Brass, Nickel plated	Black	17	1.5	V-0	E121562-220886
815A1927-B	Flexible Cover	Black	6	1.5	V-0	E80017-250533
814A1926-B	Rigid Cover	Black	7	1.5	V-0	E121562-101513781
TFT-P-R	Terminal Kit*, Brass, Nickel plated	Red	17	1.5	V-0	E121562-220886
815A1927-R	Flexible Cover	Red	6	1.5	V-0	E80017-250533
814A1926-R	Rigid Cover	Red	7	1.5	V-0	E121562-101513781
TFT-P-E	Terminal Kit*, Brass, Nickel plated	Blue	17	1.5	V-0	E121562-220886
815A1927-E	Flexible Cover	Blue	6	1.5	V-0	E80017-250533
814A1926-E	Rigid Cover	Blue	7	1.5	V-0	E121562-101513781
812A1925	O-Ring for TFT Terminal	Black	0.2	1.5	V-0	Material = EPDM
825A1959	Gasket for TFT Terminal	Black	0.3	1.5	V-0	E80017-250533
813A1930	Panel Nut	Black	4	1.5	V-0	E121562-220886

*Terminal Kit = one Terminal + one Panel Nut + two Bolts + two Split Washers, all parts in a small poly bag
 **UL Material Yellow Cards can be downloaded from ULprospector.com



Rebling Datasheet: 100 amp TFT-style Feed-through Terminal

Mounting and Assembly

Panel Thickness - Minimum	0.025" (0.6 mm)	
Maximum	0.157" (4.0 mm)	
Torque on M5 Bolts:		
Recommended	15 in-lbs (1.7 Nm)	electrical performance does not get better or worse above 15 in-lbs (1.7 Nm)
Maximum Recommended	25 in-lbs (2.8 Nm)	a Grade 4, M5 stainless bolt will snap at 50 in-lbs (5.6 Nm),
Torque on Panel Nut (with or without O-Ring):		
Recommended	15 in-lbs (1.7 Nm)	all datasheet parameters were tested at this torque level
Maximum Recommended	25 in-lbs (2.8 Nm)	the panel nut will begin to deform at 40 in-lbs (4.5 Nm)
Maximum Crimp Lug Tongue Width:		
with Flexible Cover	0.90" (23 mm)	
with Rigid Cover	0.80" (20 mm)	

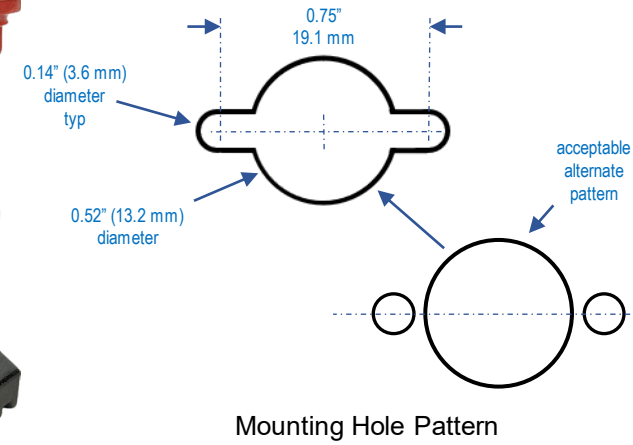

Application Notes

- Watertight is superior to IP68:** Rebling terminals are completely watertight to a depth of 20 meters which is superior to any IP Rating. The definitions of IP67, IP68 and IP69k per IEC 60529 state that "water may penetrate the seal but shall do no harm", a condition that is unacceptable to lithium battery designers.
- Panel Nut Wrench:** the hexagonal panel nut can be tightened using either a 27mm or 1 1/16" socket wrench.
- Minimum Separation between Adjacent Terminals:** the minimum centerline to centerline distance between the mounting holes of adjacent TFT terminals is 1.36" (34.6mm). This is based upon the maximum outside dimension of the panel nut or flexible cover (1.22"), the outside diameter of a 27mm socket (1.42") and a reasonable clearance margin (0.040"). This separation distance is based upon the TFT's geometry and is not a requirement for any performance parameter.
- Loctite (Thread Locking Fluid) Warning: some thread-locking fluids can cause a terminal's plastic body to crack.** Loctite's datasheets warn that its products should not be used near any thermoplastic because their fluid (or its vapor) can change the chemical structure of thermoplastic, causing stress cracks to appear weeks or months after the fluid was applied to metal bolts on or near a terminal.
- Recommended crimp lug P/Ns:** see table on right

Mfg	2 AWG (32 mm ²)	4 AWG (19 mm ²)	6 AWG (13 mm ²)	8 AWG (8 mm ²)	10 AWG (5 mm ²)	12 AWG (3 mm ²)	14 AWG (2 mm ²)
TE	330301	33114	52197	31807	130191	130191	130106
T&B	G926	F10261	E10261	D10361	K10-10R		K14-10R
Panduit	P2-10R	P4-10R	P6-10R	P8-10R	P10-10R		P14-10R
Burndy	----	YAD4CM5E10	YAD6CM5E10	YAD8CM5E10	YAV10H		YAV14H

O-Ring Application Tool

To apply an O-Ring to the ultra-compact TFT Terminal:

1. Download the application tool's step file from our website then print the tool on a 3D printer
2. Place the tool onto the pins of the TFT terminal
3. Roll the O-Ring down the tool and into the O-Ring groove



REBLING About Us Electrical Connectors Custom Molding Molded Std Parts Admin

Lithium Battery Terminals

Wherever you find a battery module larger than a loaf of bread, you will find Rebling's terminals. Equipping your design with these watertight, single-pole, wrench disconnect battery terminals will enable system integrators to easily incorporate your power modules into the MicroGrid, Reserve Power, Vehicle Electrification or APU systems the end-user requires, regardless of battery chemistry. Whether you are coupling battery modules in series for a stationary power application, a liquid-cooled motive power system, a single SLI module, a telecom or data center reserve power system or simply bringing DC power from the inside to the outside of a panel, our terminals, covers and accessories are designed with your application in mind. Rebling Feed-throughs are the lowest cost terminals for 100Ah to 10 kWh lithium batteries.

Resources
 Overview PDF of all Terminals
 Cable & Terminal Design Guide
 Terminal Selection Guide
 UL Approval Procedure
 CE Approval Procedure

Download 3D Step Files

100 amp TFT-style Lithium Battery Terminal

Our TFT terminal (without mounting ears) which will be available in Red, Black, and Blue in Q4 2022. This 100 amp terminal will be available with or without Fixed-Orientation Ridges, can accommodate 8 AWG to 2 AWG (8 mm² to 34 mm²) cables, and will have snap-on Flexible and Rigid Covers. Unlike our SFT style Terminal, the TFT-style Terminal does not require panel mounting screws, because it has molded-in...

STP File Download

Terminal Covers, O-Rings, Tools, & Gaskets:

TFT MFT
 LFT BFT
 SFT XFT

DOWNLOAD STP FILES